

## CONFIGURATIONS

### WASTE TYPES



Channel Drain

## PRODUCT FEATURES

- Made from Lightweight Rigid Polyurethane
- Flexibility with the size, shape and drain position eliminates expensive structural floor changes.
- Can be installed onto solid timber, particle board, concrete or slate/tile sub floors.
- The ProFinish installation process simplifies the resource consent procedure.
- Provides an instant slope for tiled showers while creating a professional finish
- Custom Options Available

## SPECIFICATIONS

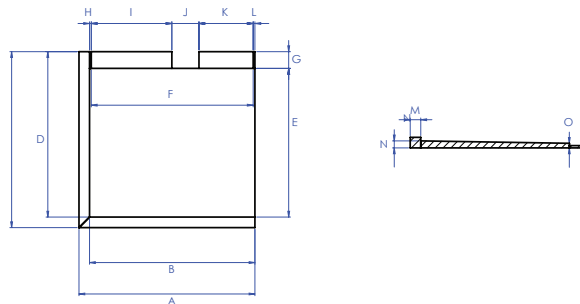

CHROME	BLACK		A	B	C	D	E	F	G	H	I	J	K	L
PRO8923	PRO1060	ProFinish Package Recessed 2S 870x870 Channel Drain	870	870	775	820	95	25	408	154	258	25	39	26
PRO8930	PRO1077	ProFinish Package Recessed 2S 870x970 Channel Drain	870	970	875	820	95	25	408	154	258	25	40	26
PRO8909	PRO1046	ProFinish Package Recessed 2S 870x1070 Channel Drain	870	1070	975	820	95	25	408	154	258	25	42	26
PRO8916	PRO1053	ProFinish Package Recessed 2S 870x1170 Channel Drain	870	1170	1075	820	95	25	408	154	258	25	44	26
PRO8985	PRO1107	ProFinish Package Recessed 2S 970x870 Channel Drain	970	870	775	920	95	25	458	154	308	25	39	26
PRO8992	PRO1114	ProFinish Package Recessed 2S 970x970 Channel Drain	970	970	875	920	95	25	458	154	308	25	40	26
PRO8961	PRO1084	ProFinish Package Recessed 2S 970x1070 Channel Drain	970	1070	975	920	95	25	458	154	308	25	42	26
PRO8978	PRO1091	ProFinish Package Recessed 2S 970x1170 Channel Drain	970	1170	1075	920	95	25	458	154	308	25	44	26
PRO8527	PRO9005	ProFinish Package Recessed 2S 1070x870 Channel Drain	1070	870	775	920	95	75	458	154	308	75	39	26
PRO8534	PRO9012	ProFinish Package Recessed 2S 1070x970 Channel Drain	1070	970	875	920	95	75	458	154	308	75	40	26
PRO8503	PRO1121	ProFinish Package Recessed 2S 1070x1070 Channel Drain	1070	1070	975	920	95	75	458	154	308	75	42	26
PRO8510	PRO1138	ProFinish Package Recessed 2S 1070x1170 Channel Drain	1070	1170	1075	920	95	75	458	154	308	75	44	26
PRO8572	PRO9043	ProFinish Package Recessed 2S 1170x870 Channel Drain	1170	870	775	1120	95	25	558	154	408	25	39	26
PRO8589	PRO9050	ProFinish Package Recessed 2S 1170x970 Channel Drain	1170	970	875	1120	95	25	558	154	408	25	40	26
PRO8558	PRO9029	ProFinish Package Recessed 2S 1170x1070 Channel Drain	1170	1070	975	1120	95	25	558	154	408	25	42	26
PRO8565	PRO9036	ProFinish Package Recessed 2S 1170x1170 Channel Drain	1170	1170	1075	1120	95	25	558	154	408	25	44	26

### DESCRIPTION:

The ProFinish™ Tile Tray System is made in New Zealand from high density, environmentally safe, rigid polyurethane, and replaces the need for a traditional sand and cement sloped tile shower base.

Since its launch with Jigsaw, the ProFinish™ Tile Tray System has expanded to include the premade Tile Tray, Wedge Tile Tray with Channel Drain Kit, Barrier Free Floor System and Recessed Tile Shelf; all made from the same high density, rigid polyurethane.

The ProFinish™ Tile Tray System offers flexibility, as trays can be custom manufactured to suit individual requirements. ProFinish™ Trays are easy to install, can accommodate either a channel drain or standard tile waste, are suitable for above floor or recessed application, and can be manufactured to accommodate virtually any waste position.

The ProFinish™ Tile Tray System is bonded to the floor, using compliant “Wet Area” wall linings, a continuous waterproofing membrane on floors, tray and up the walls. This whole enclosure is then ready for tiling.

### CONTRIBUTIONS TO COMPLIANCE

B2.3.1 (b) and B2.3.2: The Newline ProFinish™ shower system, when exposed to normal conditions of the environment and subjected use, are intended to have serviceable minimum life period of 20 years and be compatible with ceramic and stone tile finishes that have a serviceable life of between 15 to 25 years. Refer to Appraisal for more information.

E3.3.2 and E3.3.6: The Newline ProFinish™ Shower System will prevent the passage of moisture from penetrating behind wall linings or entering concealed spaces. All surfaces of the membrane must have a finished surface of ceramic or stone tile. Full list of fall positions and compliance standards are outlined in Appraisal document.

F2.3.1: The Newline ProFinish™ Shower System is made from a rigid polyurethane base that does not give rise to harmful concentrations. Refer to Appraisal for more information.

### SCOPE OF USE

The Newline ProFinish™ Shower System is intended for use in the following environments:

- Buildings where an enclosed shower tray system and impervious waterproof membrane is required to floor and wall wet areas as defined in E3/AS2 to prevent damage to building elements and adjoining structures.
- Suitable for uses in applications such as residential housing, commercial bathrooms, hotels and apartments.
- For full scope of use required, refer to Appraisal and Installation Instructions.

### WARNINGS AND BANS

This product is not subject to warning or bans under section 26 of the Building Act 2004.

### CONTACT DETAILS

Location: NZ for Local and Imported Products

Legal and Trading Name of Manufacturer: Newline Group Ltd

Importer Address for Service: 54 Unutoto Place, Tauranga, 3171

Importer Website: [newline.nz](http://newline.nz)

Importer Email: [info@newline.co.nz](mailto:info@newline.co.nz)

Importer Phone Number: 0508 NEWLINE

### CONDITIONS OF USE

- Refer to appraisal for full scope of system. The ProFinish system must be installed according to the ProFinish Installation manual.
- When designed and installed correctly, no maintenance of the Newline ProFinish™ shower system is required or is achievable. A regular check of the finished surfaces must be made to ensure it remains fully adhered to the substrate. Any cracks or damage that may occur to the finished surface must be repaired by a professional tradesperson immediately. Refer to Product Appraisal and Newline Maintenance Document for more information.
- Product should be installed by an experienced installer or tradesperson to ensure best outcome.

### SUPPORTING DOCUMENTATION

The following additional documentation supports the above statements:

[ProFinish Installation Manual](#)

[Warranty Information](#)

[ProFinish Appraisal Document](#)